



HERCULUX Chengdu HercuLux Photoelectric
 恒坤光电 Technology Co.,Ltd
Product Approval

Approval number :

Customer :

Manufacturer : Chengdu HercuLux Photoelectric Technology Co.,Ltd

PN	Code	Product
HK-35@18-10-XHP35-01-1g-1	1. 01. 81601 S	HK 35@18-10° Degree lens
HK-35@18-10-XHP35-01-1g-1	1. 01. 81601_1	HK 35@18-10° degree lens_01
HK-12@04-0253-S	1. 01. 81601_2	HK 35@18-10 ° Cover_02



Supplier confirmation				Client confirmation			
Proposed		DATE		Qualified <input type="checkbox"/>		DATE	
Project manager		DATE		Unqualified <input type="checkbox"/>		DATE	
Audit		DATE		Audit		DATE	
Approved		DATE		Approved		DATE	
Stamp		DATE		Stamp		DATE	

(Confirmation of acceptance by both parties must be signed and sealed)

Factory: Chengdu Shuangliu District, Iot industrial park 2 road HercuLux Photoelectric Park

Phone : 028-85887727 (801) 028-85887990 (801)

Fax : 028-85887730

<http://www.herculux.cn/>

Sales Dept: Shenzhen Nanshan District Nanshan Cloud Valley Innovation Industrial Park Comprehensive Service Building, 501-

TEL: 0755-2937 1541

FAX: 0755-2907 5140

*Approval In duplicate , for both supplier and customer.



HERCULUX
恒坤光电

Product Approval

TEL: 0755-2937 1541

FAX: 0755-2907 5140

<http://www.herculux.cn/>

Date updated: 2022/5/13

Product Picture:	
PN:	HK-35@18-10-XHP35-01-1g-1
Size(L*W*H/Φ*H):	Φ:30mm*H:11.5mm
Material:	PC
Efficiency:	\
Temperature(Topr):	Material extreme temperature resistance : -40°C to +120°C long-term use temperature : -40°C to +100°C
FWHM:	10°
Matched LES:	3535

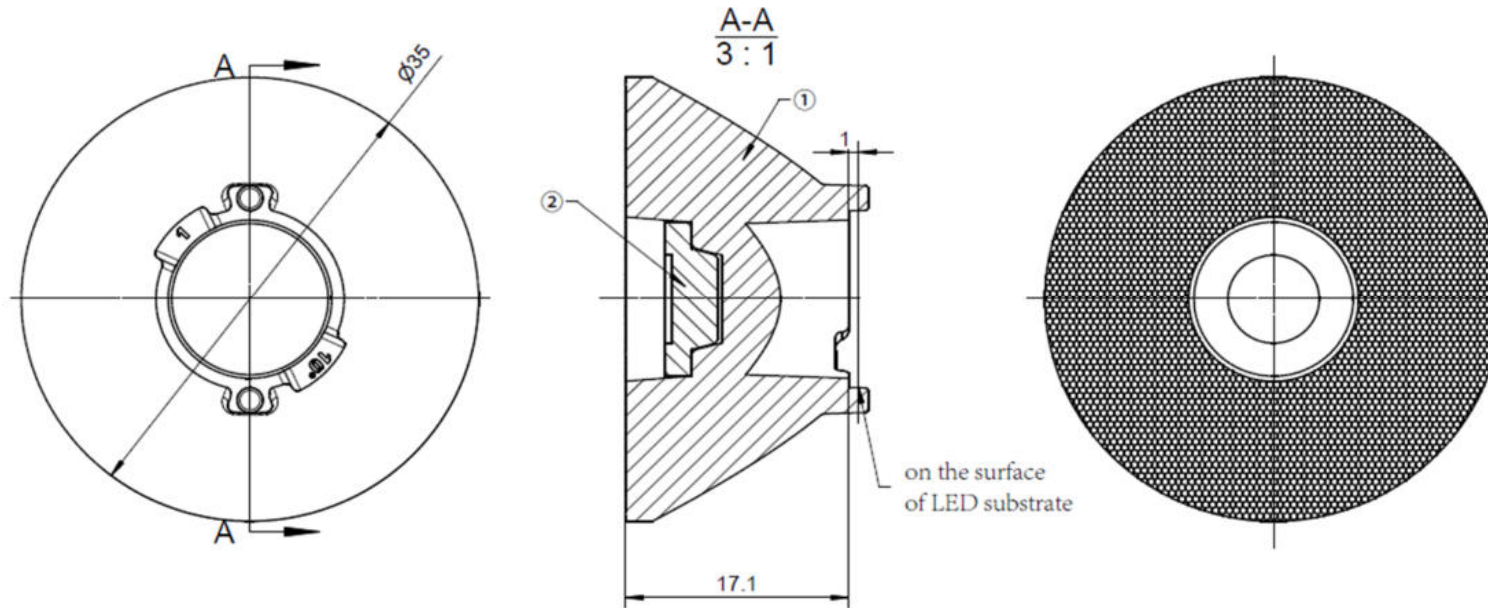

Technical remark:

1. The 3D map is not indicated for rounded corners and draft angle.
2. The dimensional tolerances are not specified according to GB/T 14486 2008 MT5.
3. The surface has no flash, shrinkage, bubbles and other defects.

NO.	Code	Product Name	PN	Product material
①	1.01.81601_1	HK 35@18-10° degree lens_01	HK-35@18-10-XHP35-01-1g-1	PC
②	1.01.81601_2	HK 35@18-10 ° Cover_02	HK-12@04-0253-S	PC White
Optical design			HK-35@18-10-XHP35-01-1g-1	
Structure design			1.01.81601 S	
Review			number of drawing	qty weight
Validation			Material:	CDHK

MT5 Tolerance table (mm)	Basic size	<3	3~10	24~65	65~140	140~250	250~450	>450
	olerance value	±0.1	±0.15	±0.35	±0.50	±0.80	±1.2	±2.0

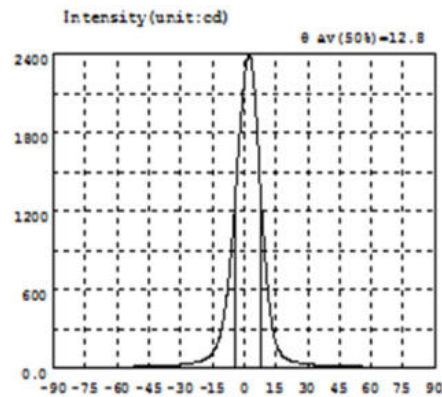
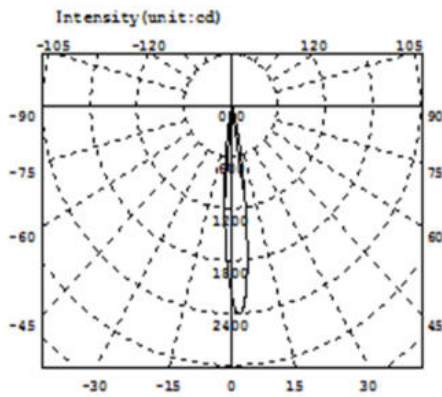

Intensity data:(deg , cd) C0-180

A	I	A	I	A	I	A	I	A	I	A	I
-90.0	0.5197	-58.5	6.681	-27.0	30.06	4.5	2176	36.0	18.70	67.5	4.805
-88.5	0.6218	-57.0	7.121	-25.5	33.69	6.0	1832	37.5	17.12	69.0	4.429
-87.0	0.7916	-55.5	7.561	-24.0	37.78	7.5	1409	39.0	15.80	70.5	4.098
-85.5	0.9614	-54.0	8.014	-22.5	42.82	9.0	1020	40.5	14.70	72.0	3.804
-84.0	1.097	-52.5	8.467	-21.0	49.16	10.5	703.9	42.0	13.87	73.5	3.554
-82.5	1.256	-51.0	8.907	-19.5	57.89	12.0	464.4	43.5	13.11	75.0	3.314
-81.0	1.438	-49.5	9.405	-18.0	70.41	13.5	281.4	45.0	12.20	76.5	3.024
-79.5	1.642	-48.0	10.03	-16.5	88.74	15.0	185.0	46.5	11.54	78.0	2.546
-78.0	1.880	-46.5	10.74	-15.0	115.7	16.5	127.8	48.0	11.03	79.5	2.171
-76.5	2.166	-45.0	11.34	-13.5	157.0	18.0	94.02	49.5	10.37	81.0	1.972
-75.0	2.655	-43.5	11.86	-12.0	219.5	19.5	73.12	51.0	9.787	82.5	1.770
-73.5	3.092	-42.0	12.45	-10.5	311.7	21.0	59.48	52.5	9.276	84.0	1.598
-72.0	3.362	-40.5	13.26	-9.0	458.3	22.5	50.12	54.0	8.850	85.5	1.451
-70.5	3.599	-39.0	14.09	-7.5	662.5	24.0	43.66	55.5	8.473	87.0	1.325
-69.0	3.853	-37.5	15.12	-6.0	922.1	25.5	38.73	57.0	8.080	88.5	1.213
-67.5	4.139	-36.0	16.30	-4.5	1236	27.0	34.79	58.5	7.661	90.0	1.121
-66.0	4.455	-34.5	17.69	-3.0	1587	28.5	31.45	60.0	7.191		
-64.5	4.831	-33.0	19.35	-1.5	1930	30.0	28.40	61.5	6.746		
-63.0	5.249	-31.5	21.29	0.0	2205	31.5	25.47	63.0	6.250		
-61.5	5.700	-30.0	23.78	1.5	2370	33.0	22.86	64.5	5.741		
-60.0	6.183	-28.5	26.71	3.0	2367	34.5	20.60	66.0	5.263		

Electricity Parameter:

Current I: 0.1000A Power: 3.200W
Voltage V: 32.00V PF: 1.000

Optical Parameter (Distance=2.410m):

Equivalent Luminous flux: $\Phi_{eff} = 223.81\text{lm}$ Efficiency: $Eff=69.96\text{lm/W}$
Diffuse angle: @ (25%): 18.9deg @ (50%): 12.8deg @ (75%): 8.2deg @ (50%): 12.8deg
Diffuse angle: @ (25%): 19.5deg @ (50%): 13.7deg @ (75%): 9.3deg @ (50%): 13.7deg
Imax=2392cd (C=0.0deg,G=2.0deg) C0-180Plane Imax= 2392cd(G=2.0deg)
C0-180Plane I0= 2205cd

		Standard size	Upper Size limit	Lower size limit	Test result1	Test result2	Test result3	Test result4	Judgment	Remarks
1.Size	diameter	35			34.94					Test environment: in 20 °C -25 °C environment to achieve thermal equilibrium after the test
	height	17.1			17.23					
	Gate shear can not affect the appearance of the lamp									
See attachment "Appearance Inspection Standards"										

2.Appearance Quality	See attachment "Appearance Inspection Standards"	E	No burr	No burr	No burr	No burr	OK
			No stains	No stains	No stains	No stains	

3.Material	PC			Color	Transparent		OK
------------	----	--	--	-------	-------------	--	----

4.Optical index	Testing LED	3535									
	The recommended size and power rating of the LED light source recommended for this lens should be comparable to the source of the test, if it is required to be out of range. According to the heat dissipation capability of the lamp and the actual conditions of the use environment, the lens should be fully tested and tested to prevent the lens life.										
	FWHM	See light distribution curve									
	angle		12.8	13.3	12.3						
	K-value		10.72	11.075	12.03						
Facula	See the signature sample										

Comprehensive judgment	Qualified									
------------------------	-----------	--	--	--	--	--	--	--	--	--

Remarks:

1、 Tool Number: V-Vernier Caliper 2D-Quadratic H-Height Gauge M-Tool Microscope P-Needle T-Thick Gauge R-Radius Gauge E-Visual.

2、 Ambient temperature on the size of the product refer to the table on the right

PC product size changes with temperature table

Temperature (°C)	50mm	100mm	150mm	200mm	250mm	300mm
0	0.00	0.00	0.00	0.00	0.00	0.00
10	0.05	0.08	0.12	0.15	0.18	0.22
20	0.10	0.15	0.22	0.28	0.35	0.42
30	0.15	0.22	0.30	0.38	0.48	0.58
40	0.20	0.28	0.38	0.48	0.60	0.72

Precautions:

- Please wear clean gloves during the lens assembly process to prevent the lens surface from being contaminated.
- Try to avoid touching the total reflection surface when taking the lens.
- The lens surface is contaminated. Only use a soft cotton cloth dipped in analytically pure neutral solvent to wipe gently. Do not wipe with industrial solvents (alcohol, isopropanol, acetone, ether, toluene, xylene, carbon tetrachloride, MMA Body, etc.).
- The working temperature of the lens should be within the temperature resistance limit of the lens material. Exceeding the temperature resistance limit will cause the lens to crack or melt and affect the service life of the lens. It is recommended that the upper surface temperature of the LED colloid should be less than 120 degrees.

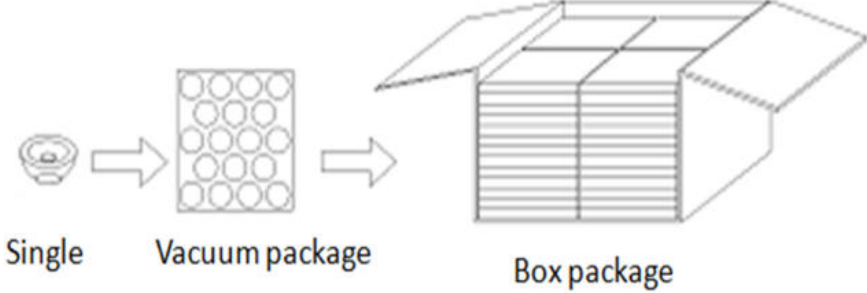
PN	HK-35@18-10-XHP35-01-1g-1		Product Name	HK 35@18-10° Degree lens			
Product material	PC		Customer				
Package diagram	 <p style="text-align: center;">Single Vacuum package Box package</p>						
Product packing	18	A/ Box	4	pcs/Layer			
	13	Layer/Box	936	A/ Carton			
Packaging Materials	NO.	Part No	Part name	Size	Dosage	Unit	Remarks
	1	2.07.0042	Blister box	23cm*21cm	52	BAG	
	2	2.08.0001	PE film	30cm*30cm	52	PCS	
	3	2.06.0005	Reel label paper	6.2cm*8cm	52	PCS	
	4	2.06.0005	Box label paper	6.2cm*9.2cm	1	PCS	
	5	2.06.0003	big plate	46.8cm*42.8cm	14	PCS	
	6	2.06.0015	big flat carton	48cm*44cm*19cm	1	PCS	
Remarks	The loose packing is not subject to this specification. Customer's requirements shall prevail						

Special notice

When glue pass through holes, columns and other structures, or part of the thin structure, will form a weld line. The product which uses multi-point injection welding line will appear because of the combination of sol, as shown below:

Syntner

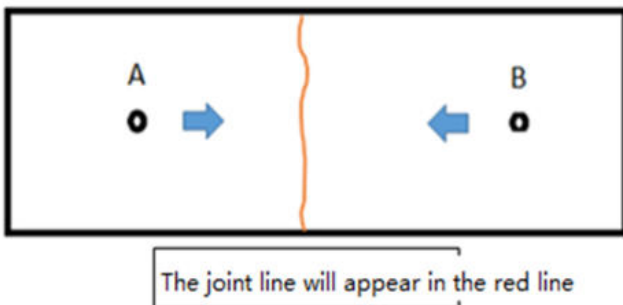
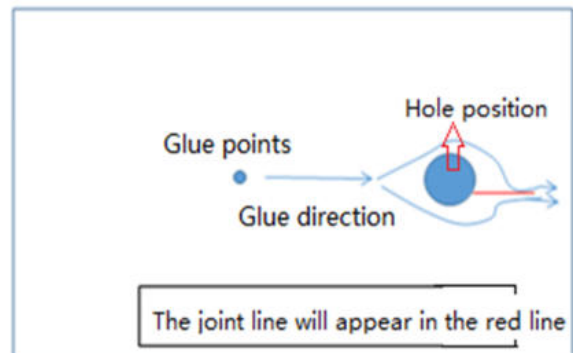
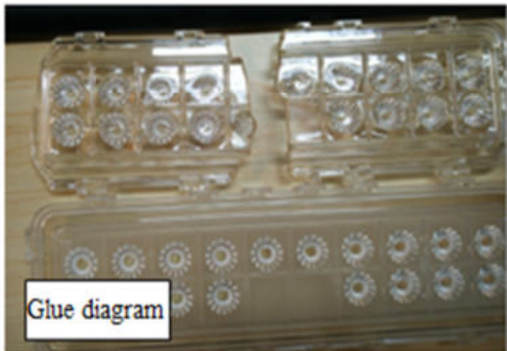
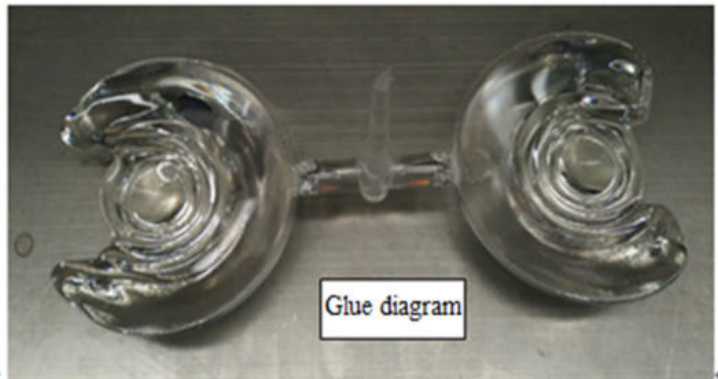

Please note :

The appearance of lines in the structure of the product as well as at the screw hole is a normal phenomenon, will not affect the actual use of the product, and can not be avoided at this stage.

Appearance inspection standards

1 Operating procedures

1.1.1 Sampling standards, sampling plan and AQL

Test level : GB/T2828.1-2012 The first part is according to the acceptance quality limit (AQL) retrieval batch inspection sampling plan, general inspection level II level, CR class defect coefficient 0, MA defect rejection level AQL = 0.65, MI class defect rejection level AQL = 1.0; defect level please see 5.4.

2 Code table

Code	Code description	Unit	Code		Code description	Unit
N	Amount/pcs	pcs	D		Diameter	mm
L	Length	mm	H		Depth	mm
W	Width	mm	DS		Distance	mm
S	Proportion	mm ²	SS		Offset	mm

3 Test conditions

3.1 Sight distance and working hours: Sight distance should be 30-35cm, each side of the inspection time does not exceed 12s, the visual angle of 45-135 degrees;

3.2 Light: 2x40w cool white fluorescent lamp, the light source is 500-550mm away from the lens surface; in order to make the appearance defect can be correctly recognized, the illumination should be 500-1000Lux, and the observation time is 10 seconds.

3.3 Visual inspection staff should be 1.0 (including corrected visual acuity) above, no color blindness, color weakness.

4 Appearance inspection standards

Test items	Judging standard	Inspection equipment	Defect level		
		Testing method	MI	MA	CR
Check the sample	When start the machine and process, all products have to check the appearance of the sample, the appearance of the sample is divided into qualified samples and limited samples.	Sample comparison , visual			
	1: Qualified sample refers to the appearance and structure standard of the product which recognized by the client, the sample size should be confirmed before mass production;				

	2: The limited sample refers to the limit of a particular exceptionally developed sample. Limit the sample only for its specific point of exception to confirm; The priority is higher than the other criteria in this table. When there is a limited sample, the limit sample shall prevail.				
Raw edge	Not allowed to affect the size and assembly	Visual, point card		√	
Scratch	1: Non-optical surface and non-exposed surface scratches should be visually insignificant and the length is less than 1/10 of the maximum surface size.	Visual, point card, calipers		√	
Fingerprint	Fingerprints are not allowed on all products	Visual		√	
Foreign objects, black spots, white spots	The product may not be attached to foreign objects, including oil, fiber, dregs of water gap and so on				√
Deformation	Insufficient filling shall not affect the appearance of the assembly and the exposed surfaces.	Visual, feeler			√
Poor ejection	Products may not appear bad ejection, including no convex top, thimble printed on the assembly surface shall not be higher than the product surface, non-assembled surface thimble height should not exceed the product size tolerances; thimble printing should be less than the product surface and no more than 0.3; thimble surface treatment should be consistent with the product side.	Visual, point card		√	
	Ejection strain: the optical surface and the appearance of the exposed surface after assembly are not allowed to have a strain, and the structural surface does not allow visual obvious strain.				
Insufficient filling	Insufficient filling shall not affect the appearance of the assembly and the exposed surfaces , The signature sample shall prevail.	Visual, point card		√	
Shrink	When the entire surface of the product shrinks, the optical properties and dimensions must meet the requirements, and the visual will not significantly affect the appearance.Part shrink reference point defects	Visual, point card		√	
Flow marks、Welding line	1 : Product does not allow the presence of flow marks and welding lines unless the structure can not be avoided;	Visual		√	
	2: The remaining flow marks shall not appear in the optical surface, a single L ≤ 10mm, no more than two				

Bubble	No bubbles are allowed	Visual		√	
Foreign objects, black spots, white spots	Not obvious or $D \leq 0.3\text{mm}$ black spots and foreign bodies in the area of 100x100mm not more than 1; Exceeded foreign matter black spots is judged bad.	Visual, point card	√		
Damaged	No damage is allowed	Visual			√
Cold glue	Optical surface may not have cold glue, non-optical surface cold glue should meet the visual is not obvious.	Visual	√		
Bad incision	1: Do not affect the product size, shall not penetrate the optical surface, the cut should be smooth;	Visual			√
	2: Laser cutting products, the optical surface burns shall not occur after the processing is completed. Beading must not affect product installation				
	3: Three molds and hot runner gate shall not appear residue.				
Scrub	Scrub surface should be uniform, off the scrub phenomenon should not be obvious , A single off scrub imprint requires $D \leq 1\text{ mm}$ and no more than 1 area within a 50x50 mm area	Visual		√	



HERCULUX
恒坤光电

Chengdu HercuLux Photoelectric
Technology Co.,Ltd
Product Approval

Approval number :

Effective date of approval :

Customer :

Product : HK-35@18-XX-D4. 5-01-1g-1

Material Code : 1.01.7935_PC、1.01.7936_PC、1.01.7937_PC

PN : HK-35@18-XX-D4. 5-01-1g-1

Manufacturer : Chengdu HercuLux Photoelectric Technology Co.,Ltd



Supplier confirmation				Client confirmation			
Proposed		DATE		Qualified <input type="checkbox"/>		DATE	
Project manager		DATE		Unqualified <input type="checkbox"/>		DATE	
Audit		DATE		Audit		DATE	
Approved		DATE		Approved		DATE	
Stamp		DATE		Stamp		DATE	

(Confirmation of acceptance by both parties must be signed and sealed)

Factory: Chengdu Shuangliu District, Iot industrial park 2 road HercuLux Photoelectric Park

Phone : 028-85887727 (801) 028-85887990 (801)

Fax : 028-85887730

<http://www.herculux.cn/>

Sales Dept: Shenzhen Nanshan District Nanshan Cloud Valley Innovation Industrial Park Comprehensive Service Building,

TEL: 0755-2937 1541

FAX: 0755-2907 5140

*Approval In duplicate , for both supplier and customer.



HERCULUX
恒坤光电

Product Approval

TEL: 0755-2937 1541

FAX: 0755-2907 5140

<http://www.herculux.cn/>

Date updated: 2020/12/14

Product Picture:	
PN:	HK-35@18-XX-D4.5-01-1g-1
Size(L*W*H/Φ*H):	Φ 35mm ; H18mm
Material:	PC
Efficiency:	>80%
Temperature(Topr):	/
FWHM:	15°24°36°
Matched LES:	CREE 1304、LUMINUS CXM-6、CITIZEN OBO

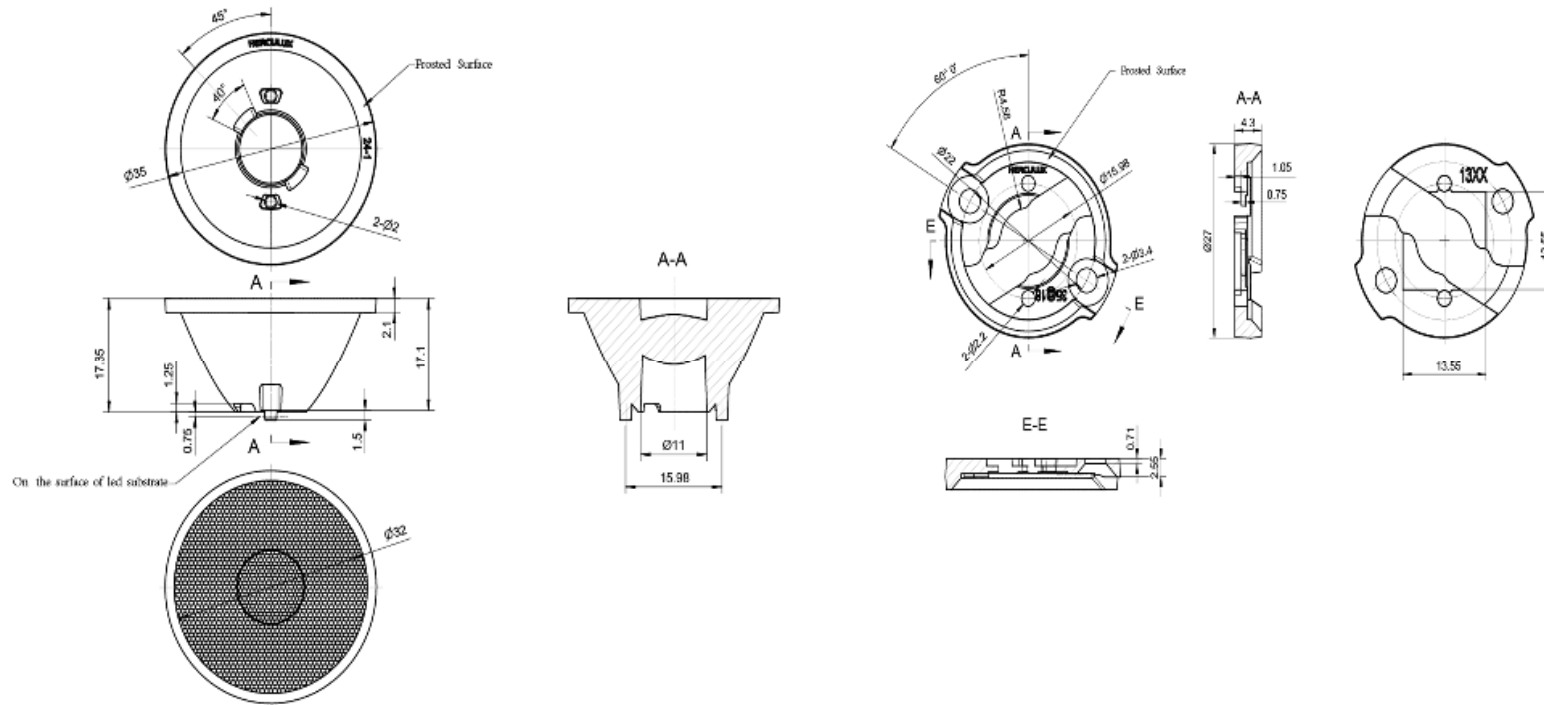

Technical Requirement:

1. The surface don't have any defects of flash, shrink and bubble.
2. The uncharted fillet and pattern draft subject to the 3D drawing.
3. The uncharted dimensional tolerance subject to the 3D drawing.

Optical Design			HK-35@18-XX-D4.5-01-1g-1		1. 01. 7936_PC、 1. 01. 7936_PC、 1. 01. 7936_PC	
Structure Design			HK-35@18-XXdegrees lens	Pages	Qty	Weight
Assess				2		
Authorized			Material:PC	CDHK		

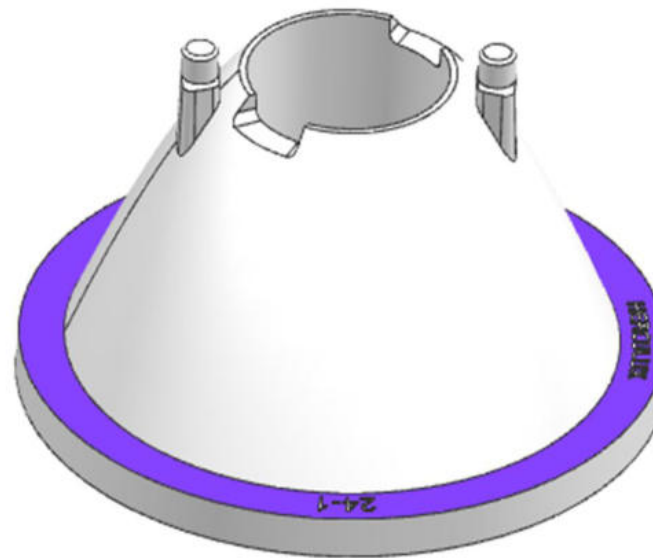
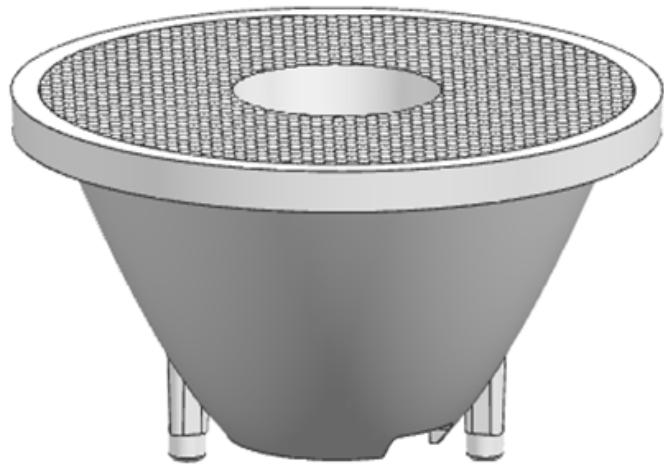

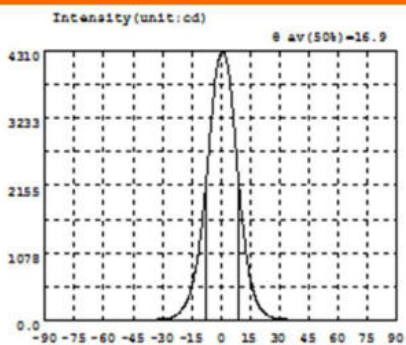
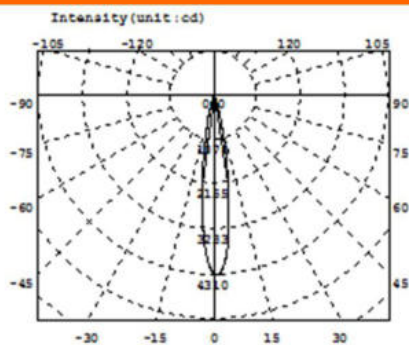

Intensity data: (deg , cd) CO-180

A	I	A	I	A	I	A	I	A	I	A	I
-90.0	0.1015	-58.5	8.108	-27.0	38.89	4.5	3848	36.0	19.28	67.5	4.090
-88.5	0.0788	-57.0	8.858	-25.5	49.73	6.0	3389	37.5	17.78	69.0	3.533
-87.0	0.1243	-55.5	9.476	-24.0	67.40	7.5	2840	39.0	16.78	70.5	3.049
-85.5	0.2387	-54.0	10.20	-22.5	98.48	9.0	2255	40.5	16.16	72.0	2.694
-84.0	0.4987	-52.5	10.94	-21.0	143.1	10.5	1755	42.0	15.69	73.5	2.330
-82.5	0.7224	-51.0	11.45	-19.5	196.9	12.0	1324	43.5	15.20	75.0	1.951
-81.0	0.8978	-49.5	11.82	-18.0	268.2	13.5	966.9	45.0	14.66	76.5	1.626
-79.5	1.112	-48.0	12.18	-16.5	375.5	15.0	687.2	46.5	14.24	78.0	1.405
-78.0	1.378	-46.5	12.34	-15.0	531.6	16.5	495.4	48.0	13.82	79.5	1.247
-76.5	1.582	-45.0	12.63	-13.5	724.4	18.0	351.2	49.5	13.30	81.0	1.010
-75.0	1.841	-43.5	13.08	-12.0	975.3	19.5	239.0	51.0	12.66	82.5	0.8409
-73.5	2.162	-42.0	13.57	-10.5	1312	21.0	170.4	52.5	11.91	84.0	0.5840
-72.0	2.507	-40.5	14.15	-9.0	1744	22.5	123.3	54.0	11.04	85.5	0.4368
-70.5	2.967	-39.0	14.88	-7.5	2214	24.0	88.86	55.5	10.12	87.0	0.1956
-69.0	3.474	-37.5	15.73	-6.0	2743	25.5	63.87	57.0	9.191	88.5	0.1039
-67.5	4.034	-36.0	16.89	-4.5	3300	27.0	47.77	58.5	8.427	90.0	0.1117
-66.0	4.611	-34.5	18.93	-3.0	3793	28.5	38.06	60.0	7.627		
-64.5	5.329	-33.0	21.10	-1.5	4098	30.0	31.56	61.5	6.827		
-63.0	6.026	-31.5	23.70	0.0	4268	31.5	27.05	63.0	6.100		
-61.5	6.611	-30.0	27.24	1.5	4287	33.0	23.59	64.5	5.356		
-60.0	7.352	-28.5	31.75	3.0	4139	34.5	21.22	66.0	4.665		

Electricity Parameter:

Current I: 0.1000A Power: 3.650W
Voltage V: 36.50V PF: 0.000

Optical Parameter (Distance=2.410m) :

Equivalent Luminous flux: Φ_{eff} = 522.9lm Efficiency: Eff=143.27lm/W

Diffuse angle: @ (25%) : 24.5deg @ (50%) : 16.9deg @ (75%) : 11.1deg @ (50%) : 16.9deg

Diffuse angle: @ (25%) : 24.5deg @ (50%) : 17.0deg @ (75%) : 11.2deg @ (50%) : 17.0deg

I_{max}=4300cd (C=0.0deg,C=1.0deg)

CO-180Plane I_{max}= 4300cd(C=1.0deg)

CO-180Plane I₀= 4268cd

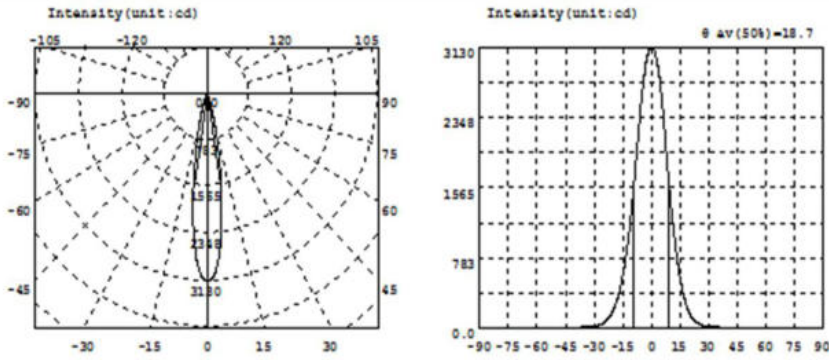

Intensity data:(deg , cd) C0-180

A	I	A	I	A	I	A	I	A	I	A	I
-90.0	0.1128	-58.5	6.971	-27.0	44.65	4.5	2739	36.0	16.01	67.5	3.481
-88.5	0.1021	-57.0	7.734	-25.5	58.14	6.0	2426	37.5	14.71	69.0	3.070
-87.0	0.1695	-55.5	8.540	-24.0	79.99	7.5	2047	39.0	13.71	70.5	2.634
-85.5	0.3171	-54.0	9.313	-22.5	116.3	9.0	1660	40.5	12.94	72.0	2.258
-84.0	0.4758	-52.5	10.18	-21.0	170.0	10.5	1327	42.0	12.29	73.5	1.959
-82.5	0.6681	-51.0	10.95	-19.5	234.6	12.0	1031	43.5	11.87	75.0	1.683
-81.0	0.8147	-49.5	11.59	-18.0	322.7	13.5	775.8	45.0	11.53	76.5	1.426
-79.5	1.006	-48.0	11.96	-16.5	439.3	15.0	566.2	46.5	11.23	78.0	1.247
-78.0	1.142	-46.5	12.25	-15.0	593.4	16.5	413.8	48.0	11.00	79.5	1.091
-76.5	1.315	-45.0	12.60	-13.5	777.2	18.0	282.8	49.5	10.63	81.0	0.8605
-75.0	1.575	-43.5	12.79	-12.0	1005	19.5	194.0	51.0	10.19	82.5	0.6583
-73.5	1.880	-42.0	13.23	-10.5	1290	21.0	130.0	52.5	9.619	84.0	0.4937
-72.0	2.145	-40.5	13.75	-9.0	1634	22.5	90.23	54.0	8.932	85.5	0.2690
-70.5	2.527	-39.0	14.66	-7.5	1990	24.0	64.91	55.5	8.222	87.0	0.2143
-69.0	2.948	-37.5	15.83	-6.0	2355	25.5	48.85	57.0	7.518	88.5	0.1015
-67.5	3.370	-36.0	17.19	-4.5	2681	27.0	38.00	58.5	6.896	90.0	0.1444
-66.0	3.839	-34.5	18.96	-3.0	2929	28.5	30.95	60.0	6.316		
-64.5	4.397	-33.0	21.30	-1.5	3070	30.0	25.81	61.5	5.708		
-63.0	4.968	-31.5	24.27	0.0	3126	31.5	22.10	63.0	5.054		
-61.5	5.604	-30.0	28.64	1.5	3095	33.0	19.40	64.5	4.504		
-60.0	6.299	-28.5	35.09	3.0	2963	34.5	17.52	66.0	3.962		

Electricity Parameter:

Current I: 0.1500A Power: 3.350W
Voltage V: 33.50V PF: 0.000

Optical Parameter (Distance=2.410m):

Equivalent Luminous flux: Φ_{eff} = 443.3lm Efficiency: $Eff = 132.33lm/W$
Diffuse angle: θ (25%): 26.8deg θ (50%): 18.7deg θ (75%): 12.3deg θ (50%): 18.7deg
Diffuse angle: θ (25%): 26.8deg θ (50%): 18.7deg θ (75%): 12.3deg θ (50%): 18.7deg
Imax=3126cd (C=0.0deg,C=0.0deg) C0-180Plane Imax= 3126cd(C=0.0deg)
C0-180Plane IO= 3126cd

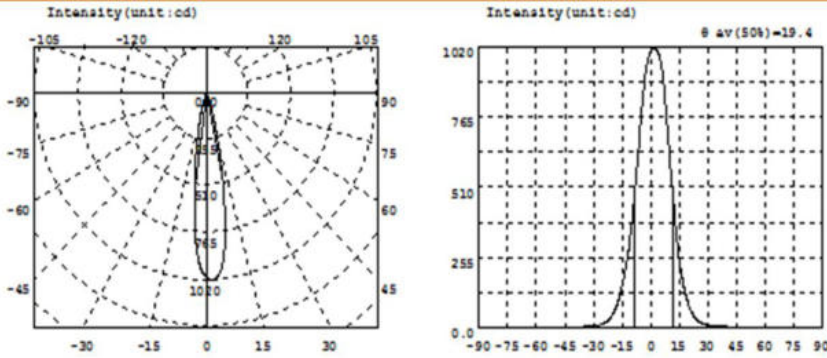

Intensity data: (deg , cd) C0-180

A	I	A	I	A	I	A	I	A	I	A	I
-90.0	0.0790	-58.5	2.131	-27.0	11.89	4.5	985.3	36.0	6.567	67.5	1.437
-88.5	0.1573	-57.0	2.334	-25.5	14.84	6.0	930.7	37.5	6.007	69.0	1.270
-87.0	0.1472	-55.5	2.545	-24.0	19.33	7.5	832.3	39.0	5.530	70.5	1.130
-85.5	0.1918	-54.0	2.794	-22.5	26.78	9.0	702.7	40.5	5.171	72.0	0.9716
-84.0	0.1712	-52.5	3.016	-21.0	39.05	10.5	574.5	42.0	4.952	73.5	0.8398
-82.5	0.2148	-51.0	3.169	-19.5	55.04	12.0	454.4	43.5	4.752	75.0	0.7278
-81.0	0.3507	-49.5	3.271	-18.0	77.51	13.5	336.6	45.0	4.598	76.5	0.6147
-79.5	0.4174	-48.0	3.368	-16.5	110.2	15.0	246.9	46.5	4.462	78.0	0.5337
-78.0	0.4181	-46.5	3.430	-15.0	154.7	16.5	182.7	48.0	4.315	79.5	0.4834
-76.5	0.4776	-45.0	3.523	-13.5	203.5	18.0	131.2	49.5	4.081	81.0	0.3416
-75.0	0.6343	-43.5	3.628	-12.0	263.5	19.5	91.69	51.0	3.892	82.5	0.3189
-73.5	0.7013	-42.0	3.778	-10.5	344.0	21.0	63.64	52.5	3.706	84.0	0.2256
-72.0	0.7957	-40.5	3.970	-9.0	446.0	22.5	45.40	54.0	3.496	85.5	0.1606
-70.5	0.8516	-39.0	4.264	-7.5	556.8	24.0	32.12	55.5	3.174	87.0	0.0853
-69.0	1.043	-37.5	4.624	-6.0	681.1	25.5	23.05	57.0	2.884	88.5	0.1128
-67.5	1.189	-36.0	5.029	-4.5	805.6	27.0	17.19	58.5	2.609	90.0	0.0033
-66.0	1.247	-34.5	5.536	-3.0	909.8	28.5	13.56	60.0	2.380		
-64.5	1.405	-33.0	6.273	-1.5	969.4	30.0	11.11	61.5	2.148		
-63.0	1.577	-31.5	7.160	0.0	1001	31.5	9.364	63.0	1.922		
-61.5	1.791	-30.0	8.222	1.5	1016	33.0	8.081	64.5	1.778		
-60.0	1.916	-28.5	9.767	3.0	1010	34.5	7.294	66.0	1.582		

Electricity Parameter:

Current I: 0.1500A Power: 0.8390W
 Voltage V: 8.399V PF: 0.000

Optical Parameter (Distance=2.410m):

Equivalent Luminous flux: Φ_{eff} = 152.2lm Efficiency: Eff = 181.50lm/W
 Diffuse angle: θ (25%) : 27.0deg θ (50%) : 19.4deg θ (75%) : 13.3deg θ (50%) : 19.4deg
 Diffuse angle: θ (25%) : 27.1deg θ (50%) : 19.6deg θ (75%) : 13.5deg θ (50%) : 19.6deg
 I_{max} = 1016cd (C=0.0deg, G=2.0deg) C0-180Plane I_{max} = 1016cd (G=2.0deg)
 C0-180Plane I₀ = 1001cd

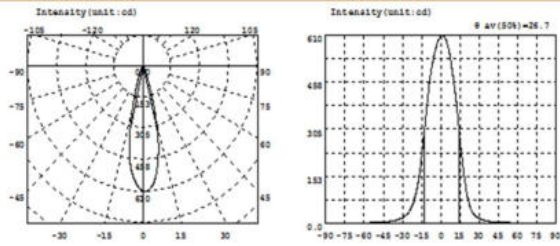

Intensity data: (deg , cd) CO-180

A	I	A	I	A	I	A	I	A	I
-90.0	0.0113	-58.5	2.591	-27.0	28.54	4.5	587.6	36.0	0.111
-88.5	0.0454	-57.0	2.895	-25.5	34.87	6.0	505.4	37.5	7.872
-87.0	0.0902	-55.5	3.183	-24.0	43.60	7.5	534.1	39.0	6.950
-85.5	0.1133	-54.0	3.490	-22.5	56.32	9.0	491.5	40.5	6.289
-84.0	0.1921	-52.5	3.836	-21.0	74.19	10.5	445.9	42.0	5.761
-82.5	0.2386	-51.0	4.198	-19.5	96.76	12.0	395.9	43.5	5.361
-81.0	0.3394	-49.5	4.596	-18.0	127.3	13.5	334.7	45.0	5.011
-79.5	0.4673	-48.0	5.025	-16.5	167.4	15.0	271.5	46.5	4.705
-78.0	0.4984	-46.5	5.437	-15.0	215.1	16.5	216.6	48.0	4.408
-76.5	0.5776	-45.0	5.895	-13.5	270.6	18.0	164.7	49.5	4.098
-75.0	0.6689	-43.5	6.363	-12.0	332.6	19.5	119.2	51.0	3.778
-73.5	0.7689	-42.0	6.899	-10.5	395.5	21.0	83.59	52.5	3.492
-72.0	0.8694	-40.5	7.515	-9.0	452.0	22.5	59.51	54.0	3.194
-70.5	0.9320	-39.0	8.246	-7.5	494.7	24.0	42.79	55.5	2.920
-69.0	1.068	-37.5	9.194	-6.0	529.1	25.5	32.00	57.0	2.637
-67.5	1.228	-36.0	10.38	-4.5	556.3	27.0	25.09	58.5	2.391
-66.0	1.430	-34.5	11.96	-3.0	579.0	28.5	20.65	60.0	2.179
-64.5	1.633	-33.0	13.98	-1.5	595.3	30.0	17.35	61.5	1.945
-63.0	1.839	-31.5	16.37	0.0	605.3	31.5	14.63	63.0	1.746
-61.5	2.075	-30.0	19.38	1.5	607.7	33.0	12.35	64.5	1.580
-60.0	2.324	-28.5	23.38	3.0	601.5	34.5	10.57	66.0	1.377

Electricity Parameter:

Current I: 0.1500A Power: 0.8300W
 Voltage V: 8.300V PF: 0.000

Optical Parameter (Distance=2.410m):

Equivalent Luminous flux: Φ_{eff} = 151.8lm Efficiency: Eff=182.97lm/W
 Diffuse angle: θ (25%): 35.3deg θ (50%): 26.7deg θ (75%): 18.9deg θ (50%): 26.7deg
 Diffuse angle: θ (25%): 35.4deg θ (50%): 26.9deg θ (75%): 19.1deg θ (50%): 26.9deg
 Imax=607.9cd (C=0.0deg, C=1.0deg) CO-180Plane Imax= 607.9cd(C=1.0deg)
 CO-180Plane IO= 605.3cd

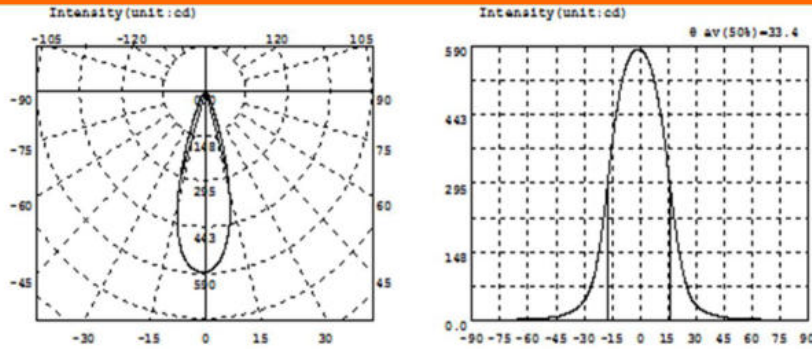

Intensity data: (deg , cd) C0-180

A	I	A	I	A	I	A	I	A	I	A	I	A	I
-90.0	0.1354	-58.5	4.405	-27.0	65.84	4.5	556.3	36.0	17.81	67.5	2.618		
-88.5	0.2032	-57.0	4.745	-25.5	83.34	6.0	539.1	37.5	15.50	69.0	2.339		
-87.0	0.2820	-55.5	5.082	-24.0	107.0	7.5	516.0	39.0	13.48	70.5	2.055		
-85.5	0.3620	-54.0	5.486	-22.5	139.0	9.0	486.9	40.5	11.87	72.0	1.838		
-84.0	0.4977	-52.5	5.963	-21.0	178.5	10.5	455.5	42.0	10.47	73.5	1.627		
-82.5	0.6113	-51.0	6.469	-19.5	222.2	12.0	419.6	43.5	9.282	75.0	1.451		
-81.0	0.7696	-49.5	7.037	-18.0	273.2	13.5	377.1	45.0	8.239	76.5	1.302		
-79.5	0.8941	-48.0	7.698	-16.5	326.5	15.0	322.9	46.5	7.493	78.0	1.210		
-78.0	1.041	-46.5	8.525	-15.0	379.2	16.5	275.5	48.0	6.849	79.5	1.123		
-76.5	1.234	-45.0	9.545	-13.5	423.9	18.0	229.7	49.5	6.247	81.0	1.032		
-75.0	1.448	-43.5	10.68	-12.0	462.3	19.5	185.3	51.0	5.739	82.5	0.9619		
-73.5	1.643	-42.0	12.15	-10.5	496.6	21.0	145.7	52.5	5.306	84.0	0.9166		
-72.0	1.904	-40.5	13.93	-9.0	524.5	22.5	114.6	54.0	4.923	85.5	0.9250		
-70.5	2.246	-39.0	16.12	-7.5	545.6	24.0	88.58	55.5	4.576	87.0	0.9150		
-69.0	2.583	-37.5	18.55	-6.0	561.9	25.5	67.83	57.0	4.268	88.5	0.9149		
-67.5	2.851	-36.0	21.60	-4.5	572.6	27.0	52.12	58.5	4.010	90.0	0.9577		
-66.0	3.089	-34.5	25.37	-3.0	578.9	28.5	41.60	60.0	3.753				
-64.5	3.326	-33.0	30.01	-1.5	581.2	30.0	33.94	61.5	3.533				
-63.0	3.586	-31.5	35.44	0.0	580.9	31.5	28.16	63.0	3.309				
-61.5	3.814	-30.0	42.54	1.5	577.4	33.0	23.73	64.5	3.106				
-60.0	4.108	-28.5	52.17	3.0	569.1	34.5	20.48	66.0	2.873				

Electricity Parameter:

Current I: 0.1000A Power: 3.299W
Voltage V: 33.00V PF: 1.000

Optical Parameter (Distance=2.410m) :

Equivalent Luminous flux: Φ_{eff} = 216.9lm Efficiency: Eff = 65.75lm/W
Diffuse angle: θ (25%) : 43.2deg θ (50%) : 33.4deg θ (75%) : 24.3deg θ (50%) : 33.4deg
Diffuse angle: θ (25%) : 43.2deg θ (50%) : 33.5deg θ (75%) : 24.3deg θ (50%) : 33.5deg
Imax=581.4cd (C=0.0deg,G=-1.0deg) CO-180Plane Imax= 581.4cd(C=-1.0deg)
CO-180Plane IO= 580.9cd

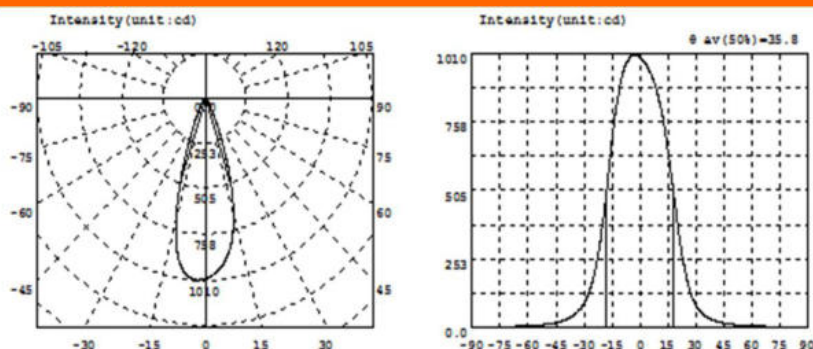

Intensity data:(deg , cd) C0-180

A	I	A	I	A	I	A	I	A	I	A	I
-90.0	0.0451	-58.5	8.298	-27.0	137.6	4.5	952.4	36.0	39.32	67.5	5.136
-88.5	0.0563	-57.0	9.026	-25.5	171.6	6.0	930.9	37.5	33.87	69.0	4.740
-87.0	0.2366	-55.5	9.700	-24.0	212.6	7.5	904.1	39.0	29.37	70.5	4.308
-85.5	0.3510	-54.0	10.56	-22.5	266.0	9.0	870.0	40.5	25.76	72.0	3.836
-84.0	0.5008	-52.5	11.58	-21.0	334.8	10.5	829.5	42.0	22.67	73.5	3.229
-82.5	0.7830	-51.0	12.79	-19.5	410.1	12.0	780.9	43.5	20.03	75.0	2.619
-81.0	1.142	-49.5	14.03	-18.0	497.5	13.5	720.5	45.0	17.68	76.5	2.163
-79.5	1.437	-48.0	15.51	-16.5	593.4	15.0	648.7	46.5	15.86	78.0	1.651
-78.0	1.757	-46.5	17.35	-15.0	690.7	16.5	575.2	48.0	14.32	79.5	1.302
-76.5	2.197	-45.0	19.50	-13.5	771.7	18.0	498.5	49.5	12.97	81.0	1.031
-75.0	2.737	-43.5	21.90	-12.0	840.2	19.5	419.8	51.0	11.74	82.5	0.7680
-73.5	3.399	-42.0	24.75	-10.5	897.1	21.0	340.7	52.5	10.79	84.0	0.5148
-72.0	3.880	-40.5	28.35	-9.0	939.6	22.5	272.0	54.0	9.955	85.5	0.3014
-70.5	4.342	-39.0	32.82	-7.5	968.3	24.0	216.7	55.5	9.186	87.0	0.1543
-69.0	4.759	-37.5	37.83	-6.0	986.9	25.5	169.8	57.0	8.497	88.5	0.0802
-67.5	5.150	-36.0	44.13	-4.5	998.2	27.0	131.5	58.5	7.945	90.0	0.0575
-66.0	5.677	-34.5	52.25	-3.0	1002	28.5	103.7	60.0	7.456		
-64.5	6.172	-33.0	62.26	-1.5	1000	30.0	82.37	61.5	6.961		
-63.0	6.665	-31.5	73.82	0.0	994.1	31.5	66.34	63.0	6.500		
-61.5	7.132	-30.0	88.91	1.5	984.1	33.0	54.45	64.5	6.051		
-60.0	7.735	-28.5	109.5	3.0	969.7	34.5	46.01	66.0	5.610		

Electricity Parameter:

Current I: 0.1500A Power: 3.348W
 Voltage V: 33.50V PF: 0.000

Optical Parameter (Distance=2.410m) :

Equivalent Luminous flux: Φ eff= 420.6lm Efficiency: Eff=125.64lm/W
 Diffuse angle: @ (25%) : 45.8deg @ (50%) : 35.8deg @ (75%) : 26.6deg @ (50%) : 35.8deg
 Diffuse angle: @ (25%) : 46.0deg @ (50%) : 36.0deg @ (75%) : 26.9deg @ (50%) : 36.0deg
 Imax=1002cd (C=0.0deg,C=-3.0deg) C0-180Plane Imax= 1002cd(G=-3.0deg)
 C0-180Plane I0= 994.1cd

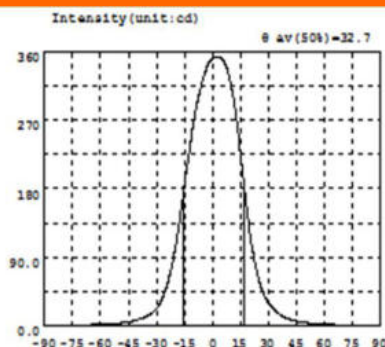
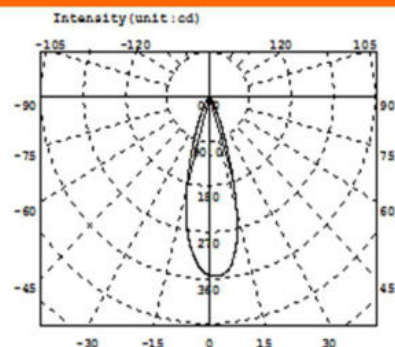

Intensity data: (deg , cd) C0-180

A	I	A	I	A	I	A	I	A	I	A	I	A	I	A	I
-90.0	0.0226	-58.5	2.590	-27.0	35.69	4.5	350.5	36.0	15.78	67.5	1.737				
-88.5	0.0225	-57.0	2.816	-25.5	44.73	6.0	346.5	37.5	13.41	69.0	1.608				
-87.0	0.1232	-55.5	2.939	-24.0	56.12	7.5	339.5	39.0	11.58	70.5	1.393				
-85.5	0.1572	-54.0	3.238	-22.5	70.65	9.0	326.0	40.5	10.05	72.0	1.278				
-84.0	0.1500	-52.5	3.522	-21.0	88.58	10.5	308.7	42.0	8.732	73.5	1.147				
-82.5	0.2846	-51.0	3.789	-19.5	108.2	12.0	286.8	43.5	7.700	75.0	0.9814				
-81.0	0.4184	-49.5	4.221	-18.0	131.3	13.5	259.0	45.0	6.764	76.5	0.8065				
-79.5	0.4940	-48.0	4.665	-16.5	157.5	15.0	226.3	46.5	6.079	78.0	0.6614				
-78.0	0.5489	-46.5	5.269	-15.0	185.5	16.5	194.4	48.0	5.464	79.5	0.4952				
-76.5	0.7370	-45.0	5.815	-13.5	208.2	18.0	162.8	49.5	4.920	81.0	0.3980				
-75.0	0.8666	-43.5	6.521	-12.0	235.6	19.5	133.1	51.0	4.453	82.5	0.3451				
-73.5	1.026	-42.0	7.357	-10.5	260.3	21.0	107.3	52.5	4.054	84.0	0.2919				
-72.0	1.182	-40.5	8.372	-9.0	281.9	22.5	87.12	54.0	3.760	85.5	0.2328				
-70.5	1.362	-39.0	9.509	-7.5	299.1	24.0	69.93	55.5	3.421	87.0	0.1729				
-69.0	1.537	-37.5	10.85	-6.0	314.5	25.5	55.95	57.0	3.118	88.5	0.0813				
-67.5	1.636	-36.0	12.36	-4.5	327.6	27.0	45.06	58.5	2.876	90.0	0.1015				
-66.0	1.728	-34.5	14.11	-3.0	338.6	28.5	37.17	60.0	2.693						
-64.5	1.905	-33.0	16.52	-1.5	346.0	30.0	30.97	61.5	2.470						
-63.0	2.045	-31.5	19.24	0.0	350.5	31.5	25.84	63.0	2.274						
-61.5	2.264	-30.0	23.09	1.5	352.6	33.0	21.72	64.5	2.089						
-60.0	2.423	-28.5	28.39	3.0	352.8	34.5	18.47	66.0	1.868						

Electricity Parameter:

Current I: 0.1500A Power: 0.8290W Voltage V: 8.300V PF: 0.000

Optical Parameter (Distance=2.410m):

Equivalent Luminous flux: # eff= 133.4lm Efficiency: Eff=160.92lm/W Diffuse angle: @ (25%): 43.4deg @ (50%): 32.7deg @ (75%): 23.3deg @ (50%): 32.7deg Diffuse angle: @ (25%): 43.4deg @ (50%): 32.9deg @ (75%): 23.6deg @ (50%): 32.9deg Imax=353.0cd (C=0.0deg,G=2.5deg) C0-180Plane Imax= 353.0cd(C=2.5deg) C0-180Plane I0= 350.5cd

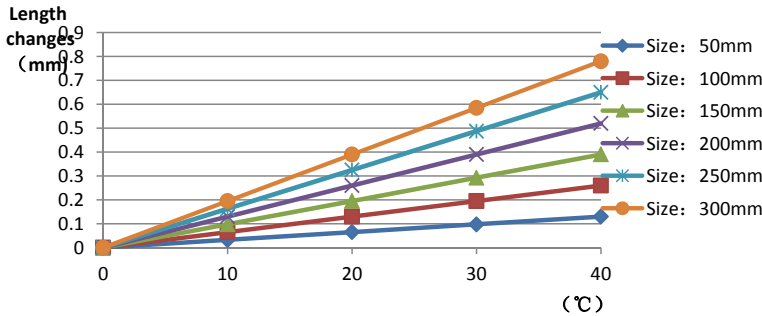
	Standard size	Upper Size limit	Lower size limit	Test result1	Test result2	Test result3	Judgment																																													
1.Size	17935 35@18-15°																																																			
	OD	35	35.1	34.85	34.97	34.91	34.99	OK																																												
	Height1	17.35	17.5	17.25	17.41	17.36	17.39	OK																																												
	Height2	17.1	17.2	17	17.1	17.11	17.16	OK																																												
	Locating column spacing	15.98	16.08	15.88	16.02	15.98	16.01	OK																																												
	17935 35@18-24°																																																			
	OD	35	35.1	34.85	34.93	34.91	34.9	OK																																												
	Height1	17.35	17.6	17.35	17.56	17.55	17.46	OK																																												
	Height2	17.1	17.25	17.1	17.18	17.19	17.18	OK																																												
	Locating column	2	2.05	1.9	1.96	1.95	1.95	OK																																												
	17935 35@18-36°																																																			
	OD	35	35.1	34.85	34.97	35.01	34.9	OK																																												
	Height1	17.35	17.55	17.35	17.48	17.5	17.5	OK																																												
	Height2	17.1	17.25	17	17.2	17.16	17.19	OK																																												
	Locating column spacing	15.98	16.08	15.78	15.89	16	15.93	OK																																												
	Gate shear can not affect the appearance of the lamp																																																			
See attachment "Appearance Inspection Standards"																																																				
2.Appearance Quality	See attachment "Appearance Inspection Standards"	E	No burr	No burr	No burr	No burr	OK																																													
			No stains	No stains	No stains	No stains																																														
3.Material	PC			Color	Transparent		OK																																													
4.Optical index	Testing LED	CREE 1304、LUMINUS CXM-6、CITIZEN OBO																																																		
	FWHM	See light distribution curve																																																		
		17935 35@18-15°			17936 35@18-24°			17937 35@18-36°																																												
	Angle	13° -17°	16.9°	16.8°	22°-26°	24.4°	24.6°	32°-38°	33.2°	33.4°	OK																																									
	Efficiency	>80%	87.45%	81.83%	>80%	84.98%	85.98%	>80%	86.02%	84.22%	OK																																									
Facula	See the signature sample																																																			
Comprehensive judgment	Qualified																																																			
Remarks:	<p>1、 Tool Number: V-Vernier Caliper 2D-Quadratic H-Height Gauge M-Tool Microscope P-Needle T-Thick Gauge R-Radius Gauge E-Visual.</p> <p>2、 Test environment: In 20 °C -25 °C environment to achieve thermal equilibrium after the test. (Ambient temperature on the size of the product refer to the table on the right)</p>																																																			
	<p style="text-align: center;">PC product size changes with temperature table</p>  <table border="1"> <caption>Data for PC product size changes with temperature table</caption> <thead> <tr> <th>Temperature (°C)</th> <th>50mm</th> <th>100mm</th> <th>150mm</th> <th>200mm</th> <th>250mm</th> <th>300mm</th> </tr> </thead> <tbody> <tr> <td>0</td> <td>0.00</td> <td>0.00</td> <td>0.00</td> <td>0.00</td> <td>0.00</td> <td>0.00</td> </tr> <tr> <td>10</td> <td>0.05</td> <td>0.08</td> <td>0.12</td> <td>0.15</td> <td>0.18</td> <td>0.22</td> </tr> <tr> <td>20</td> <td>0.10</td> <td>0.15</td> <td>0.22</td> <td>0.28</td> <td>0.35</td> <td>0.42</td> </tr> <tr> <td>30</td> <td>0.15</td> <td>0.22</td> <td>0.30</td> <td>0.38</td> <td>0.48</td> <td>0.58</td> </tr> <tr> <td>40</td> <td>0.20</td> <td>0.28</td> <td>0.38</td> <td>0.48</td> <td>0.60</td> <td>0.72</td> </tr> </tbody> </table>										Temperature (°C)	50mm	100mm	150mm	200mm	250mm	300mm	0	0.00	0.00	0.00	0.00	0.00	0.00	10	0.05	0.08	0.12	0.15	0.18	0.22	20	0.10	0.15	0.22	0.28	0.35	0.42	30	0.15	0.22	0.30	0.38	0.48	0.58	40	0.20	0.28	0.38	0.48	0.60	0.72
Temperature (°C)	50mm	100mm	150mm	200mm	250mm	300mm																																														
0	0.00	0.00	0.00	0.00	0.00	0.00																																														
10	0.05	0.08	0.12	0.15	0.18	0.22																																														
20	0.10	0.15	0.22	0.28	0.35	0.42																																														
30	0.15	0.22	0.30	0.38	0.48	0.58																																														
40	0.20	0.28	0.38	0.48	0.60	0.72																																														
Precautions:	<p>1、 Wear clean gloves during lens assembly to prevent contamination of the lens surface.</p> <p>2、 Take the lens try to avoid touching the total reflection surface.</p> <p>3、 When the lens surface contamination, you can only gently wipe with soft cotton sticky neat neutral solvent, not allowed to wipe with industrial solvents.</p>																																																			

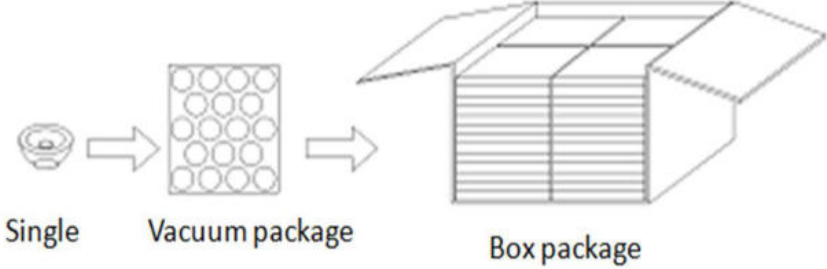
PN	HK-35@18-XX-D4.5-01-1g-1		Product Name	HK 35@18-XXdegrees lens			
Product material	PC		Customer				
Package diagram	 <p>Single → Vacuum package → Box package</p>						
Product packing	18	A/ Box	4	Box/Floor	13	Floor/Carton	
	936	A/ Carton					
Packaging Materials	NO.	Material Code	Item name	Specification	Single box usage	Unit	Remarks
	1	2.07.0042	Blister box	23cm*21cm	52	PCS	
	2	2.08.0001	PE film	30cm*30cm	52	PCS	
	3	2.06.0005	Reel label paper	62cm*42cm	1	PCS	
	4	2.06.0005	Box label paper	62cm*70cm	1	PCS	
	5	2.06.0003	big plate	36cm*46.8cm	14	PCS	
	6	2.06.0001	big carton	36cm*46.8cm*42.8cm	1	PCS	
Remarks	Scattered packaging is not subject to this specification						

Special notice

When glue pass through holes, columns and other structures, or part of the thin structure, will form a weld line. The product which uses multi-point injection welding line will appear because of the combination of sol, as shown below:

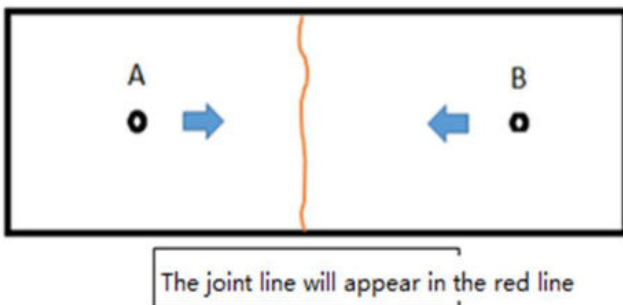
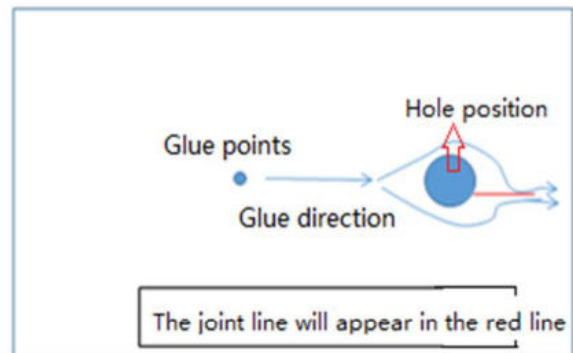
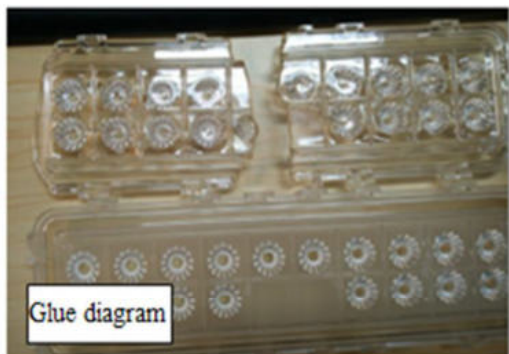
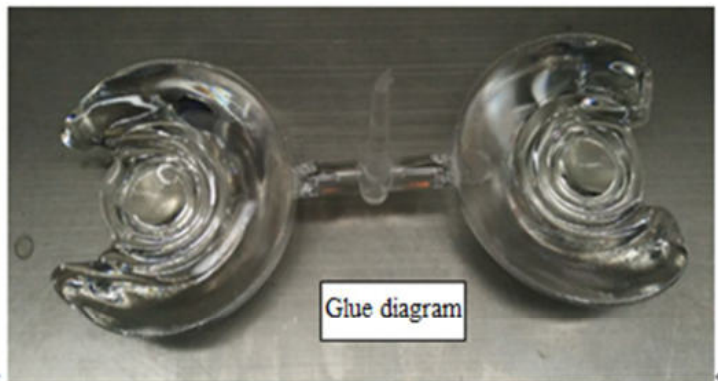

Please note :

The appearance of lines in the structure of the product as well as at the screw hole is a normal phenomenon, will not affect the actual use of the product, and can not be avoided at this stage.

Appearance inspection standards

1 Operating procedures

1.1.1 Sampling standards, sampling plan and AQL

Test level : GB/T2828.1-2012 The first part is according to the acceptance quality limit (AQL) retrieval batch inspection sampling plan, general inspection level II level, CR class defect coefficient 0, MA defect rejection level AQL = 0.65, MI class defect rejection level AQL = 1.0; defect level please see 5.4.

2 Code table

Code	Code description	Unit	Code		Code description	Unit
N	Amount/pcs	pcs	D		Diameter	mm
L	Length	mm	H		Depth	mm
W	Width	mm	DS		Distance	mm
S	Proportion	mm ²	SS		Offset	mm

3 Test conditions

3.1 Sight distance and working hours: Sight distance should be 30-35cm, each side of the inspection time does not exceed 12s, the visual angle of 45-135 degrees;

3.2 Light: 2x40w cool white fluorescent lamp, chip should be from the lens surface 500-550mm, in order to make the bad appearance can be correctly found, the illumination should not be less than 500Lux ;

3.3 Visual inspection staff should be 1.0 (including corrected visual acuity) above, no color blindness, color weakness.

4 Appearance inspection standards

Test items	Judging standard	Inspection equipment	Defect level		
		Testing method	MI	MA	CR
Check the sample	When start the machine and process, all products have to check the appearance of the sample, the appearance of the sample is divided into qualified samples and limited samples.	Sample comparison, visual			√
	1: Qualified sample refers to the appearance and structure standard of the product which recognized by the client, the sample size should be confirmed before mass production;				
	2: The limited sample refers to the limit of a particular exceptionally developed sample. Limit the sample only for its specific point of exception to confirm; The priority is higher than the other criteria in this table. When there is a limited sample, the limit sample shall prevail.				

Raw edge	Not allowed to affect the size and assembly	Visual, point card		√	
Scratch	1: Non-optical surface and non-exposed surface scratches should be visually insignificant and the length is less than 1/10 of the maximum surface size.	Visual, point card, calipers		√	
Fingerprint	Fingerprints are not allowed on all products	Visual		√	
Foreign things, impurities	The product may not be attached to foreign objects, including oil, fiber, dregs of water gap and so on				√
Deformation	Insufficient filling shall not affect the appearance of the assembly and the exposed surfaces.	Visual, feeler			√
Poor ejection	Products may not appear bad ejection, including no convex top, thimble printed on the assembly surface shall not be higher than the product surface, non-assembled surface thimble height should not exceed the product size tolerances; thimble printing should be less than the product surface and no more than 0.3; thimble surface treatment should be consistent with the product side.	Visual, point card		√	
	Ejection strain: the optical surface and the appearance of the exposed surface after assembly are not allowed to have a strain, and the structural surface does not allow visual obvious strain.				
Insufficient filling	Insufficient filling shall not affect the appearance of the assembly and the exposed surfaces , The signature sample shall prevail.	Visual, point card		√	
Shrink	When the entire surface of the product shrinks, the optical properties and dimensions must meet the requirements, and the visual will not significantly affect the appearance.Part shrink reference point defects	Visual, point card		√	
Flow marks、Welding line	1 : Product does not allow the presence of flow marks and welding lines unless the structure can not be avoided;	Visual		√	
	2: The remaining flow marks shall not appear in the optical surface, a single L ≤ 10mm, no more than two				
Bubble	No bubbles are allowed	Visual		√	
Foreign matter、Dark spots	Not obvious or $D \leq 0.3\text{mm}$ black spots and foreign bodies in the area of 100x100mm not more than 1; Exceeded foreign matter black spots is judged bad.	Visual, point card	√		
Damaged	No damage is allowed	Visual			√

Cold glue	Optical surface may not have cold glue, non-optical surface cold glue should meet the visual is not obvious.	Visual	√		
Bad incision	1: Do not affect the product size, shall not penetrate the optical surface, the cut should be smooth;	Visual			√
	2: Laser cutting products, the optical surface burns shall not occur after the processing is completed. Beading must not affect product installation				
	3: Three molds and hot runner gate shall not appear residue.				
Scrub	Scrub surface should be uniform, off the scrub phenomenon should not be obvious , A single off scrub imprint requires $D \leq 1$ mm and no more than 1 area within a 50x50 mm area	Visual		√	



HERCULUX Chengdu HercuLux Photoelectric
恒坤光电 Technology Co.,Ltd
Product Approval

Approval number :

Customer :

Product : HK 35@18-60 degree lens

Material Code : 1.01.81535

PN : HK-35@18-60-D4.5-22-1g-1

Synthetic information:1.07.81402_HK-257@02-0221-S

Manufacturer : Chengdu HercuLux Photoelectric Technology Co.,Ltd



Supplier confirmation				Client confirmation			
Proposed		DATE		Qualified <input type="checkbox"/>		DATE	
Project manager		DATE		Unqualified <input type="checkbox"/>			
Audit		DATE		Audit		DATE	
Approved		DATE		Approved		DATE	
Stamp		DATE		Stamp		DATE	

(Confirmation of acceptance by both parties must be signed and sealed)

Factory: Chengdu Shuangliu District, Iot industrial park 2 road HercuLux Photoelectric Park

Phone : 028-85887727 (801) 028-85887990 (801)

Fax : 028-85887730

www.hkoptics.com

Sales Dept: Shenzhen Nanshan District Nanshan Cloud Valley Innovation Industrial Park Comprehensive Service Building,

TEL: 0755-2937 1541

FAX: 0755-2907 5140

*Approval In duplicate , for both supplier and customer.



HERCULUX
恒坤光电

Product Approval

TEL: 0755-2937 1541

FAX: 0755-2907 5140

www.hkoptics.com

Date updated: 2020/3/4

Product Picture:	
PN:	HK-35@18-60-D4.5-22-1g-1
Size(L*W*H/Φ*H):	Φ:35mm*H:18mm
Material:	PC
Efficiency:	≥80%
Temperature(Topr):	-40°C to +120°C
FWHM:	60°
Matched LES:	CREE 1304

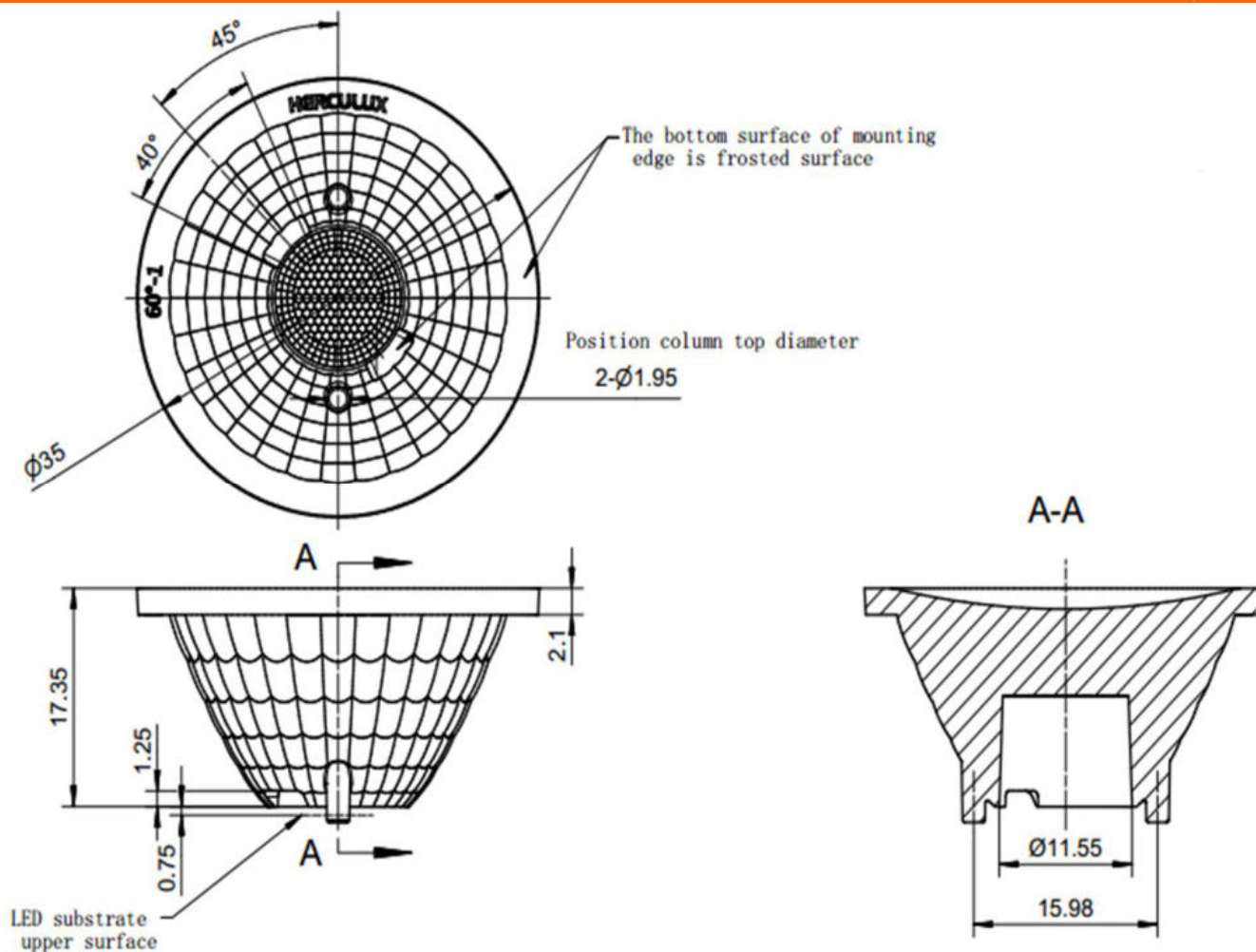

Technical Requirement:

1. The surface don't have any defects of flash, shrink and bubble.
2. The uncharted fillet and pattern draft subject to the 3D drawing.
3. The uncharted dimensional tolerance subject to the 3D drawing.

Optical Design			HK-35@18-60-D4.5-22-1g-1	1.01.81535
Structure Design		HK 35@18-60 degree lens	Pages	Qty
Assess			2	
Authorized		Material:PC		CDHK

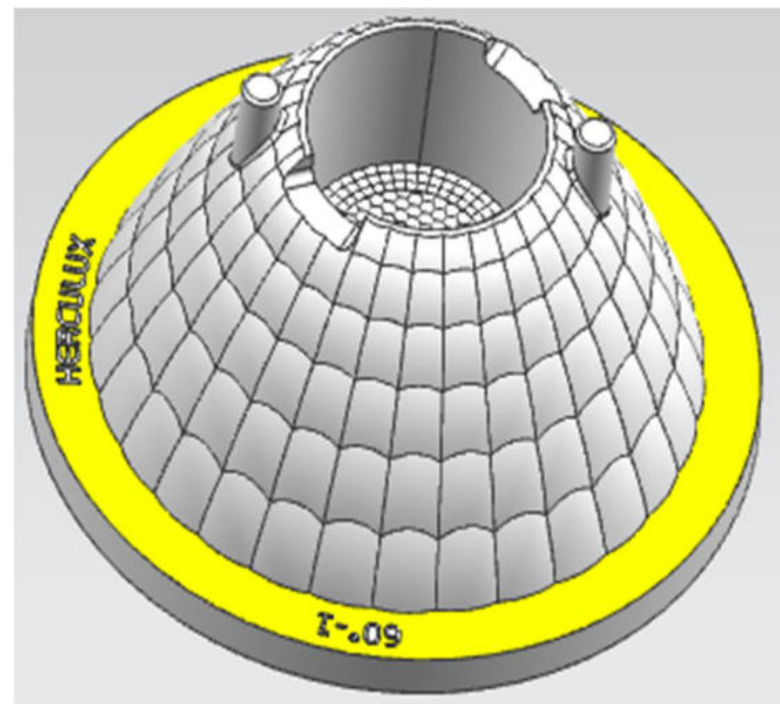
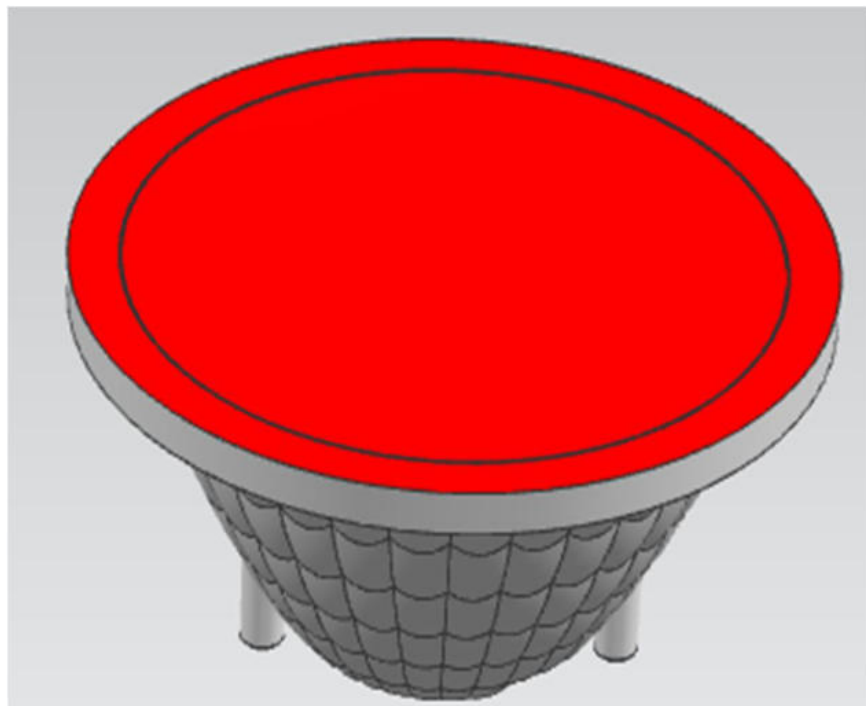

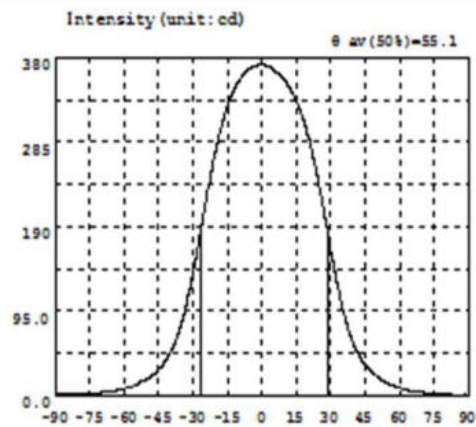
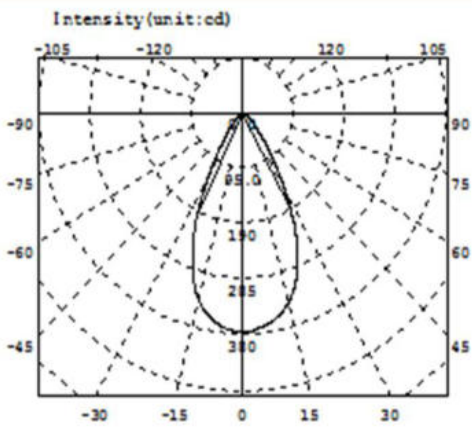

Intensity data:(deg , cd) C0-180

A	I	A	I	A	I	A	I	A	I	A	I
-90.0	1.439	-58.5	9.211	-27.0	181.0	4.5	366.8	36.0	90.51	67.5	5.148
-88.5	1.528	-57.0	10.33	-25.5	203.1	6.0	364.3	37.5	76.61	69.0	4.512
-87.0	1.567	-55.5	11.79	-24.0	224.5	7.5	361.3	39.0	65.06	70.5	3.922
-85.5	1.643	-54.0	13.82	-22.5	241.7	9.0	357.5	40.5	55.46	72.0	3.360
-84.0	1.643	-52.5	15.86	-21.0	264.5	10.5	352.7	42.0	47.59	73.5	2.891
-82.5	1.682	-51.0	17.85	-19.5	282.2	12.0	346.9	43.5	40.95	75.0	2.516
-81.0	1.811	-49.5	20.08	-18.0	298.5	13.5	339.9	45.0	35.37	76.5	2.205
-79.5	2.042	-48.0	22.74	-16.5	312.9	15.0	331.8	46.5	30.77	78.0	1.959
-78.0	2.271	-46.5	25.92	-15.0	325.1	16.5	322.4	48.0	26.88	79.5	1.767
-76.5	2.449	-45.0	29.68	-13.5	335.2	18.0	311.6	49.5	23.49	81.0	1.579
-75.0	2.669	-43.5	34.10	-12.0	343.7	19.5	298.8	51.0	20.57	82.5	1.360
-73.5	2.938	-42.0	39.52	-10.5	351.2	21.0	284.1	52.5	17.79	84.0	1.238
-72.0	3.286	-40.5	45.92	-9.0	357.2	22.5	267.4	54.0	15.26	85.5	1.197
-70.5	3.762	-39.0	53.51	-7.5	362.1	24.0	249.4	55.5	13.31	87.0	1.258
-69.0	4.310	-37.5	62.53	-6.0	365.7	25.5	229.6	57.0	11.67	88.5	1.298
-67.5	4.876	-36.0	73.42	-4.5	368.6	27.0	208.7	58.5	10.27	90.0	1.349
-66.0	5.462	-34.5	86.50	-3.0	370.7	28.5	187.0	60.0	9.117		
-64.5	6.040	-33.0	101.7	-1.5	372.0	30.0	165.4	61.5	8.124		
-63.0	6.669	-31.5	119.0	0.0	372.4	31.5	144.2	63.0	7.227		
-61.5	7.388	-30.0	138.1	1.5	371.7	33.0	124.4	64.5	6.465		
-60.0	8.247	-28.5	159.2	3.0	370.7	34.5	106.4	66.0	5.795		

Electricity Parameter:

Current I: 1.000A Power: 3.650W
 Voltage V: 36.50V PF: 1.000

Optical Parameter (Distance=2.559m) :

Equivalent Luminous flux: Φ_{eff} = 333.7lm Efficiency: Eff=91.45lm/W
 Diffuse angle: @ (25%): 69.5deg@ (50%): 55.1deg@ (75%): 41.1deg@ (50%): 55.1deg
 Diffuse angle: @ (25%): 69.5deg@ (50%): 55.1deg@ (75%): 41.1deg@ (50%): 55.1deg
 I_{max}=372.4cd (C=0.0deg,G=0.0deg) C0-180Plane I_{max}= 372.4cd(G=0.0deg)
 C0-180Plane I₀= 372.4cd

		Standard size	Upper Size limit	Lower size limit	Test result1	Test result2	Test result3	Test result4	Judgment	Remarks
1.Size	Outer diameter	35	35.1	34.8	34.9	34.89	34.88	34.9	OK	Test environment: In 20 °C -25 °C environment to achieve thermal equilibrium after the test.
	Level	17.35	17.6	17.3	17.5	17.46	17.42	17.44	OK	
	Locating column diameter	1.95	2.1	1.85	1.96	1.95	1.92	1.98	OK	
	Positioning column spacing	15.98	16.15	15.8	15.94	15.96	16.04	15.98	OK	
	Gate shear can not affect the appearance of the lamp									
See attachment "Appearance Inspection Standards"										

2.Appearance Quality	See attachment "Appearance Inspection Standards"	E	No burr	No burr	No burr	No burr	OK
			No stains	No stains	No stains	No stains	

3.Material	PC	Color	Transparent	OK
------------	----	-------	-------------	----

4.Optical index	Testing LED	CREE 1304					
	FWHM	See light distribution curve					
	Angle	51° ~61°	57°	55.1°	53.3°	57.4°	OK
	Efficiency	≥80%	87.09%	86.81%	86.26%	86.44%	OK
	Facula	See the signature sample					

Comprehensive judgment	Qualified
------------------------	-----------

Remarks:
 1、 Tool Number: V-Vernier Caliper 2D-Quadratic H-Height Gauge M-Tool Microscope P-Needle T-Thick Gauge R-Radius Gauge E-Visual.
 2、 Ambient temperature on the size of the product refer to the table on the right

PC product size changes with temperature table

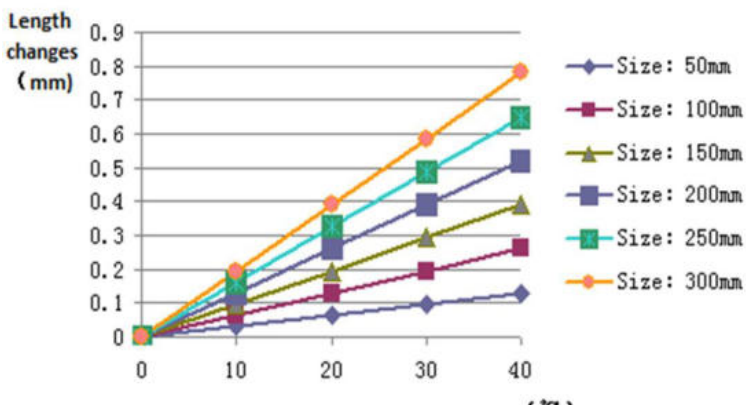

Temperature (°C)	50mm	100mm	150mm	200mm	250mm	300mm
0	0.00	0.00	0.00	0.00	0.00	0.00
10	0.05	0.10	0.15	0.20	0.25	0.30
20	0.10	0.20	0.30	0.40	0.50	0.60
30	0.15	0.30	0.45	0.60	0.75	0.90
40	0.20	0.40	0.60	0.80	1.00	1.20

- Precautions:
- 1、 Wear clean gloves during lens assembly to prevent contamination of the lens surface.
 - 2、 Take the lens try to avoid touching the total reflection surface.
 - 3、 When the lens surface contamination, you can only gently wipe with soft cotton sticky neat neutral solvent, not allowed to wipe with industrial solvents.

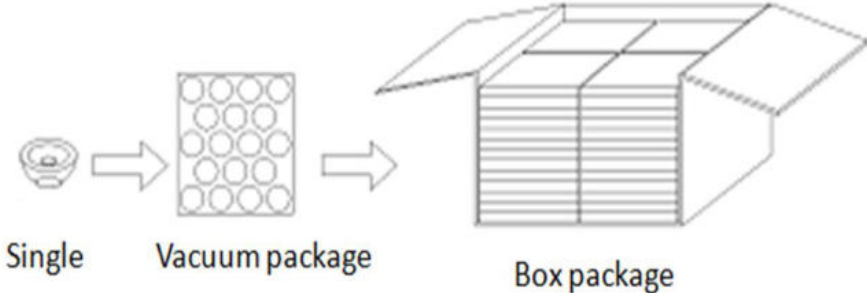
PN		HK-35@18-60-D4.5-22-1g-1		Product Name		HK 35@18-60 degree lens	
Product material		PC		Customer			
Package diagram		 <p style="text-align: center;">Single Vacuum package Box package</p>					
Product packing		18	A/box	4	Box/layer		
		13	Layer/the box	936	A/the box		
Packaging Materials	NO.	Material Code	Item name	Specification	Single box usage	Unit	Remarks
	1	2.07.0042	Blister box	23cm*21cm	52	PCS	
	2	2.08.0001	PE film	30cm*30cm	52	PCS	
	3	2.06.0005	Reel label paper	62cm*42cm	1	PCS	
	4	2.06.0005	Box label paper	62cm*70cm	1	PCS	
	4	2.06.0003	big plate	36cm*46.8cm	14	PCS	
	4	2.06.0001	big carton	36cm*46.8cm*42.8cm	1	PCS	
Remarks	Scattered packaging is not restricted by this specification, the customer has the requirements of the customer shall prevail						

Special notice

When glue pass through holes, columns and other structures, or part of the thin structure, will form a weld line. The product which uses multi-point injection welding line will appear because of the combination of sol, as shown below:

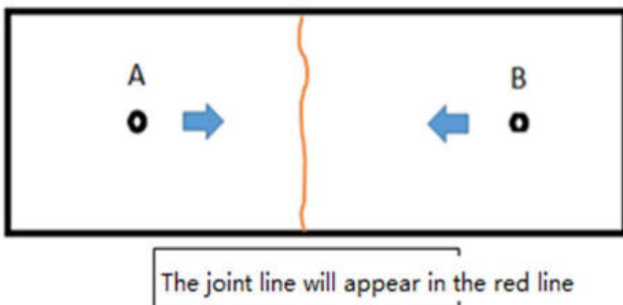
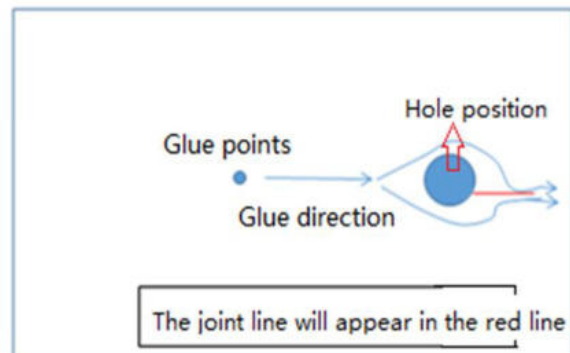
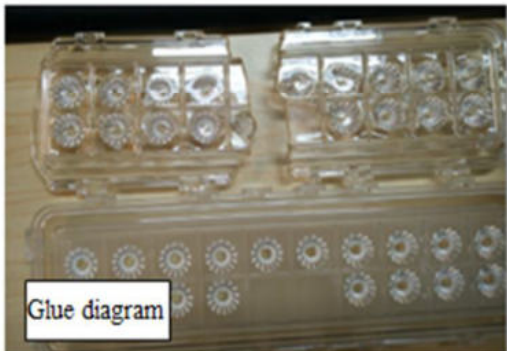
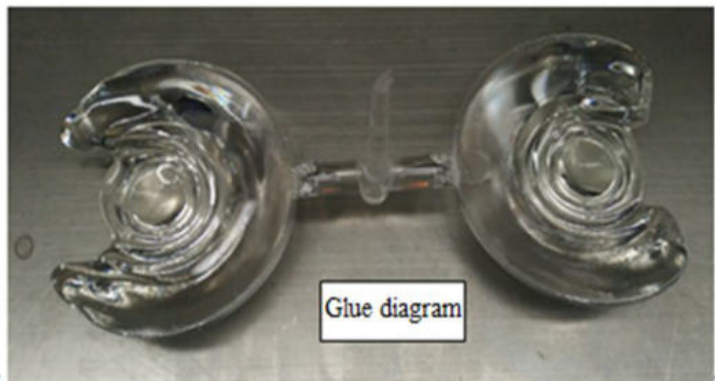

Please note :

The appearance of lines in the structure of the product as well as at the screw hole is a normal phenomenon, will not affect the actual use of the product, and can not be avoided at this stage.

Appearance inspection standards

1 Operating procedures

1.1 Sampling standards, sampling plan and AQL

Test level : GB/T2828.1-2012 The first part is according to the acceptance quality limit (AQL) retrieval batch inspection sampling plan, general inspection level II level, CR class defect coefficient 0, MA defect rejection level AQL = 0.65, MI class defect rejection level AQL = 1.0; defect level please see 5.4.

2 Code table

Code	Code description	Unit	Code	Code description	Unit
N	Amount/pcs	pcs	D	Diameter	mm
L	Length	mm	H	Depth	mm
W	Width	mm	DS	Distance	mm
S	Proportion	mm ²	SS	Offset	mm

3 Test conditions

3.1 Sight distance and working hours: Sight distance should be 30-35cm, each side of the inspection time does not exceed 12s, the visual angle of 45-135 degrees;

3.2 Light: 2x40w cool white fluorescent lamp, the light source is 500-550mm away from the lens surface; in order to make the appearance defect can be correctly recognized, the illumination should be 500-1000Lux, and the observation time is 10 seconds.

3.3 Visual inspection staff should be 1.0 (including corrected visual acuity) above, no color blindness, color weakness.

4 Appearance inspection standards

Test items	Judging standard	Inspection equipment	Defect level		
		Testing method	MI	MA	CR
Check the sample	When start the machine and process, all products have to check the appearance of the sample, the appearance of the sample is divided into qualified samples and limited samples.	Sample comparison, visual			√
	1: Qualified sample refers to the appearance and structure standard of the product which recognized by the client, the sample size should be confirmed before mass production;				
	2: The limited sample refers to the limit of a particular exceptionally developed sample. Limit the sample only for its specific point of exception to confirm; The priority is higher than the other criteria in this table. When there is a limited sample, the limit sample shall prevail.				

Raw edge	Not allowed to affect the size and assembly	Visual, point card		√	
Scratch	1: Non-optical surface and non-exposed surface scratches should be visually insignificant and the length is less than 1/10 of the maximum surface size.	Visual, point card, calipers		√	
Fingerprint	Fingerprints are not allowed on all products	Visual		√	
Foreign things, impurities	The product may not be attached to foreign objects, including oil, fiber, dregs of water gap and so on				√
Deformation	Insufficient filling shall not affect the appearance of the assembly and the exposed surfaces.	Visual, feeler			√
Poor ejection	Products may not appear bad ejection, including no convex top, thimble printed on the assembly surface shall not be higher than the product surface, non-assembled surface thimble height should not exceed the product size tolerances; thimble printing should be less than the product surface and no more than 0.3; thimble surface treatment should be consistent with the product side.	Visual, point card		√	
	Ejection strain: the optical surface and the appearance of the exposed surface after assembly are not allowed to have a strain, and the structural surface does not allow visual obvious strain.				
Insufficient filling	Insufficient filling shall not affect the appearance of the assembly and the exposed surfaces , The signature sample shall prevail.	Visual, point card		√	
Shrink	When the entire surface of the product shrinks, the optical properties and dimensions must meet the requirements, and the visual will not significantly affect the appearance.Part shrink reference point defects	Visual, point card		√	
Flow marks, Welding line	1 : Product does not allow the presence of flow marks and welding lines unless the structure can not be avoided;	Visual		√	
	2: The remaining flow marks shall not appear in the optical surface, a single L ≤ 10mm, no more than two				
Bubble	No bubbles are allowed	Visual		√	
Foreign objects, black spots, white spots	Not obvious or D ≤ 0.3mm black spots and foreign bodies in the area of 100x100mm not more than 1; Exceeded foreign matter black spots is judged bad.	Visual, point card	√		
Damaged	No damage is allowed	Visual			√
Cold glue	Optical surface may not have cold glue, non-optical surface cold glue should meet the visual is not obvious.	Visual	√		
Bad incision	1: Do not affect the product size, shall not penetrate the optical surface, the cut should be smooth;	Visual			√
	2: Laser cutting products, the optical surface burns shall not occur after the processing is completed. Beading must not affect product installation				
	3: Three molds and hot runner gate shall not appear residue.				
Scrub	Scrub surface should be uniform, off the scrub phenomenon should not be obvious , A single off scrub imprint requires D ≤ 1 mm and no more than 1 area within a 50x50 mm area	Visual		√	